

FS-1 Series Light Duty Footswitches



Features:

- Low cost foot switch for light to medium duty application
- Increase size 10% bigger than competitors product for easy operation
- Available in standard model and ergonomic (front hinged) model
- Black painted steel housing with nonskid base pad and foot treadle pad
- Switch rating: 15A (1/2HP) 125/250V AC
- Operating temperature range: -20°C to +80°C (-4°F to + 176°F)
- UL/cUL approved (E240199)
- IP20 for standard version
- Stainless housing and Water-proof to IPX8 Available on special request



Dimensions:

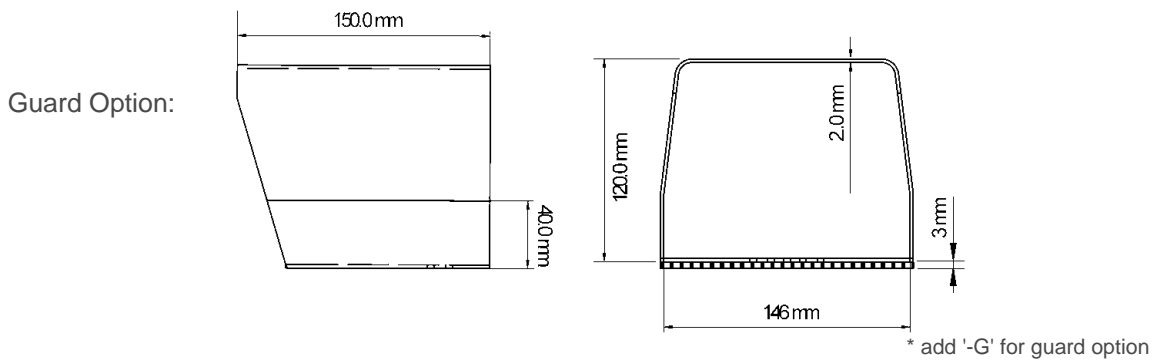
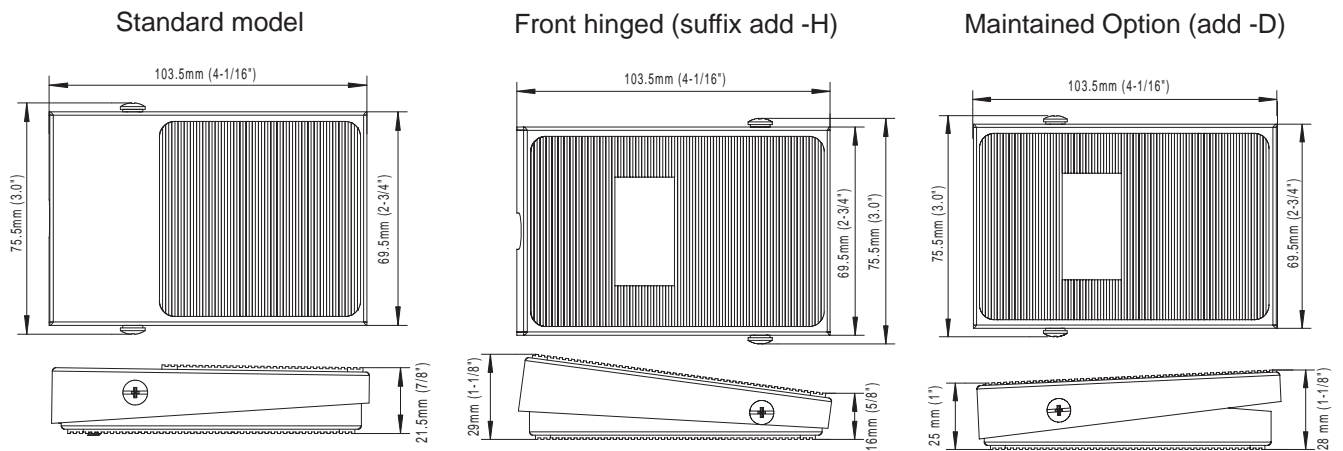

Selection Guide:

FS-1	10	D	2	-	P	Twin
	Electrical Rating	Option #1	Option #2		Option #3	Option #2
	— 10: 10A/250VAC — 15: 15A/250VAC	— D: Maintained — H: Front Hinged	— 2: Cable Length		— P: Supplied with 3 prong series plug — G: with Protective Guard — S: Stainless Steel Enclosure — K: Gold plated contact	— Blank: Single pedal — Twin: Dual Pedal